



XPort AR™ Embedded Processor Module

- ▶ A fully programmable device computing platform based on corporate IT standards – Cisco®-like CLI, XML, RSS
- ▶ Web-enable up to three electronic devices, quickly and easily
- ▶ Provide robust “data center grade” security, including SSL and SSH, for networked devices
- ▶ Offer true IEEE 802.3af compliant pass-through Power over Ethernet (PoE)

XPort
AR ARCHITECT

The Flexible, Programmable Device Computing Platform for Building Intelligent, Highly Secure and Network-ready Devices

The size of a few sugar cubes, XPort® Architect™(AR) is the first device server solution that goes beyond simple network connectivity to deliver an enterprise-grade, programmable device computing and networking platform.

This Embedded Processor Module builds on our proven XPort serial-to-Ethernet/IP technology that enables device manufacturers to add Ethernet or IP connectivity as a standard feature to their products.

XPort AR includes all the essential device computing and networking features built into a single RJ45 package – including a 120Mhz DSTni™ processor, 10/100 Base-T/TX Ethernet connection, an embedded web server and a full network operating system, including TCP/IP protocol stack.

Featuring **Evolution OS™**, our powerful new real-time embedded Networking Operating System, XPort AR now offers the ability to deliver an unprecedented level of intelligence to run a networked device. And it features an extensible, open standards-based software platform for managing the device and delivering information over the enterprise network with “data-center” grade security – including SSH and SSL support. The XPort AR also delivers IEEE 802.3af compliant pass-through Power over Ethernet (PoE).

A New Era of Machine Intelligence *Enabling Scalable, Intelligent and Autonomous Devices*

As more devices are added to the network, it is increasingly necessary that they are equipped with a certain level of intelligence so they can operate more autonomously. It is not cost-effective or practical to have humans monitoring all of the “edge” equipment on M2M and enterprise networks.

Additionally, as more equipment is networked, the need to access, collect and process the data from that equipment throughout the corporation increases in order to maximize the value of the M2M network. To make this “edge to enterprise” network a reality, the M2M devices need to operate with the same standards as traditional networking equipment found in the IT data center such as servers, routers and switches.

XPort AR with Evolution OS embedded processor module offers standards-based device computing and networking capability. It makes the M2M network scalable by adding an unprecedented level of device intelligence and policy making at the network edge. XPort AR is essentially an “IP computer” built into the device which provides the ability to gather, process and communicate information and then take appropriate pre-programmed actions. More than just a networking co-processor, it offers:

- A powerful 120 MHz processor
- Up to three serial ports
- 13 configurable GPIO pins
- Flash file system with 4 MB of available memory
- 230 Kbps serial data rate
- 1.25 MB of SRAM





LANTRONIX® EVOLUTION OS™

Machine2Mainstream™

Integrating Machines and Corporate IT Systems

The benefits of integrating 'edge' M2M networked devices into traditional corporate or enterprise network are tremendous.

A unified corporate and M2M network reduces operations costs by more effectively leveraging IT investments. Additionally, this integration differentiates a company's product or service with increased or added value and helps facilitate opportunities such as:

- Asset tracking/accounting (Sarbanes-Oxley compliance)
- Workflow improvement/monitoring/reporting
- Pro-active maintenance services
- Pre-emptive diagnosis
- Fulfillment services

Network-enabled devices increase profits over the lifecycle of equipment, enabling companies to make better use of the most important asset afforded by the networked equipment: the data gathered and information gleaned.

Open Standards; Extensible Technologies

As IT managers are increasingly being asked to integrate M2M edge networked devices at a corporate level, it is important that the tools, technology and architecture on those edge devices meet current data center equipment standards. It is also important that they are easy to integrate and built on extensible and open software technologies.

The Evolution OS Networking Operating System features key integration capabilities including:

- Cisco-like CLI configurability
- XML data transport and configurability
- RSS information feeds



Cisco-like CLI

Making the edge-to-enterprise vision a reality, XPort AR with Evolution OS uses industry-standard tools for configuration, communication and control. First, it uses Cisco-like command line interface (CLI) with syntax that is very similar to that used by data center equipment such as routers and hubs.

XML-based Architecture and Device Control

A fundamental building block for the future growth of M2M networks, XML is a standard tool for web services, data transfer and rich content management that encapsulates data into a text-based format. XML-based configuration and setup records in XPort AR make the device configuration transparent to users and administrators and easily editable with a standard text or XML editor. (Microsoft®, for example, already incorporates XML capabilities into the Office software suite.)

RSS

RSS is a rapidly emerging technology used to stream and manage on-line content. RSS support enables users to configure the XPort AR to automatically send back real-time device information over the network to a database. More powerful than simple email alerts, RSS uses XML as an underlying transport and adds intelligence to the networked device while not taxing already overloaded email systems. XPort AR also supports standard SMTP email.

PoE (Power over Ethernet)

XPort AR is the first device server to deliver true IEEE 802.3af compliant pass-through Power over Ethernet (PoE) to edge devices using both Ethernet pairs. Eliminating the need for an external power supply and associated electrician labor costs, XPort AR is ideally suited to add networking functionality in security control, medical, financial, energy metering and building automation applications.

Enterprise-grade Security

Without the need to disable any features or functionality, Evolution's hardened OS provides XPort AR the highest level of security possible. This 'data center grade' protection ensures that each device on the M2M network carries the same level of security as traditional IT networking equipment in the corporate data center.

With built in SSH and SSL, XPort AR has robust defenses to hostile Internet attacks such as denial of service (DoS) and port mapping that can be used to take down the network. XPort AR also cannot be used to bring down other devices on the network. SSH includes robust key management algorithms that:

- Verify the data received came from the proper source
- Validate that the data transferred from the source over the network is non-changed when it arrives at its destination (shared secret and hashing)
- Provide ability to run popular M2M protocols over a secure SSH connection

The XPort AR supports a variety of popular cipher technologies including AES, 3DES and RC4 and hashing algorithms such as SHA-1 and MD5. Additionally, SSL ensures secure web-based communications.

Ease of Use and Flexibility

XPort AR is ideal for companies where networking is not a core competency. The network-enabled programmable module allows designers to focus their attention on code and hardware that serves to differentiate their product, reducing costs and time to market.

Accelerating the OEM development process and reducing associated cost, XPort AR features built in manufacturing testing. With pre-loaded tests, engineers do not need to create them or load them individually. This can dramatically slash development time. The new hardware also features the flexibility of external interrupts (including one non-maskable) and timer input.



XPort AR with Evolution

Example Applications

- Real-time asset tracking
 - Integration with enterprise ERP
- Secure metering
 - SSH
- Networked PoE Access Control
 - Save power supply and installation costs
- POS Transaction Automation Terminal
 - Central processor managing system and I/O

XPort and XPort AR Family of Applications

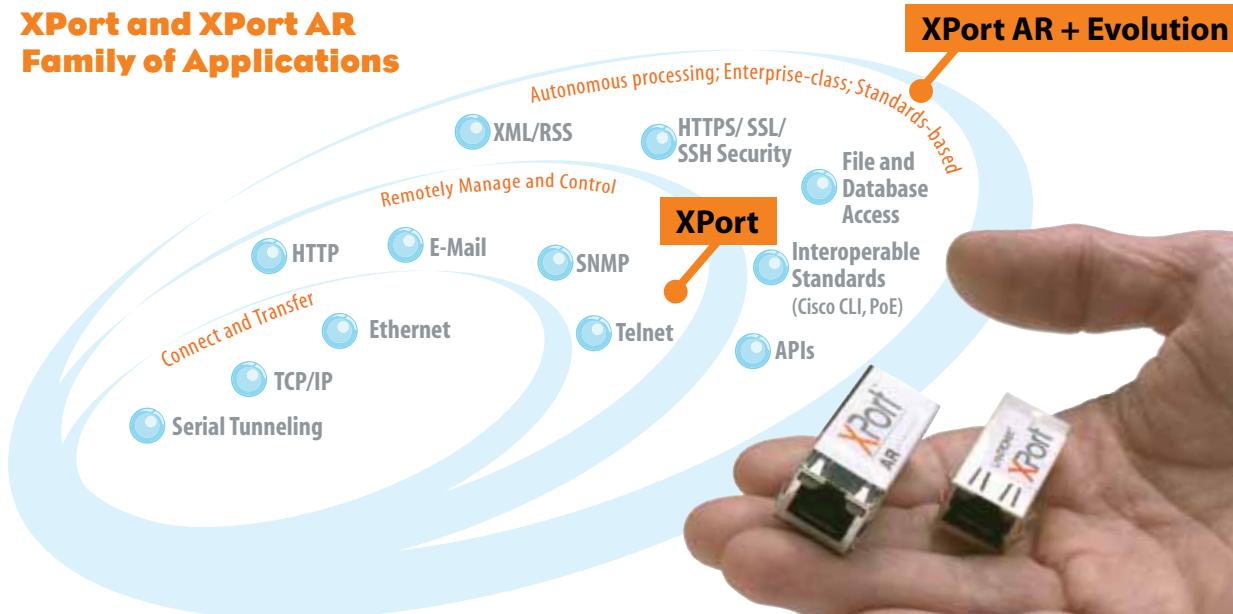

XPort is an extremely fast solution for Serial-to-Ethernet data tunneling. The new XPort AR embedded processor adds advanced computing and Machine2Mainstream communication capabilities.

LANTRONIX[®] EVOLUTION OS[™] Evolution Architecture



Features and Specifications

Architecture

CPU: Based on the DSTni-EX enhanced 16-bit, 120MHz x86 Architecture
 Memory: 1.25 MB RAM and 4 MB Flash
 Firmware: upgradeable via FTP, TFTP, Serial Ports, Internal Web Server
 Diagnostics: Built in diagnostics and comprehensive statistics

Network Interface

Interface: Ethernet 10Base-T or 100Base-TX (Auto-Sensing)
 Connector: RJ45
 Layer 3 Protocols: TCP, UDP, IP, ARP, ICMP, SSH, SSL, XML, HTTP, PPP, PAP, CHAP, DNS, SMTP, RSS, DHCP, BOOTP, AutoIP, SNMP, FTP, TFTP, Telnet, CGI

Serial Interface - up to three

Interface: CMOS (Asynchronous, 5V tolerant)
 Data Rates: 300 bps to 230,400 bps (selectable by 1 bps increments)
 Characters: 7 or 8 data bits
 Parity: Odd, even, none
 Stop Bits: 1 or 2
 Control Signals: RTS, CTS, DSR, any PIO
 Flow Control: XON/XOFF, RTS/CTS, User-Selectable Characters

Indicators (LED)

10 or 100 Base-T, Full/Half-Duplex
 Link & Activity Indicator

Operating System

RTOS Kernel with pre-emptive scheduler, multithreading, memory management semaphores and Flash file system

Management

Cisco-CLI, Internal Web Server, XML, Serial, Telnet, SSH, SSL, RSS, SNMP
 Microsoft Windows[®]-based utility for configuration

Security

SSH Client & Server, SSL, 128/256/512/1024-bit AES (Rijndael), 3DES and RC4 Encryption, Public/Private-keys, and Password Protection
 SHA-1, MD5 Hashing Algorithms
 Base-64 & Digest Authentication
 User Access Lists
 Hardened OS and Protocol Stacks

Internal Web Server

Fully Brandable
 1.25 MB internal directory-/file-based file system
 CGI/CSS based
 SSL supported

Power

Input Voltage: 3.3 VDC

Environmental

Extended Temp: -40° to 85°C (-40° to 185°F)
 Storage: -40° to 85°C (-40° to 185°F)

Packaging

Dimensions: 45.7 x 16.51 x 17.8 mm (1.80 x .65 x .70 in)
 Weight: 20 g (0.7 oz)

APPLICATIONS	TUNNELING				COMMAND & CONTROL			3rd PARTY	
APPLICATIONS SUPPORT	WEB MANAGER		XML	RSS	CONFIGURATION STORE		CFG LOGGING		
SECURITY	SSH		SSL			PACKET FILTER		PAP	
NETWORK	UDP	HTTP	CGI	DNS	RS232 MIB	MIB II	FTP		
DRIVERS	ETHERNET		SERIAL LINES		FLASH DRIVER		PIO (CP) DRIVER		
	MANUFACTURING TESTS		WATCH DOG			EEPROM			
KERNEL	THREADING MODULE		BUFFER POOLS		SEMAPHORES		TIMERS		
	PREEMPTIVE SCHEDULER		MEMORY (HEAP) MODULE			MUTUAL EXCLUSIONS			

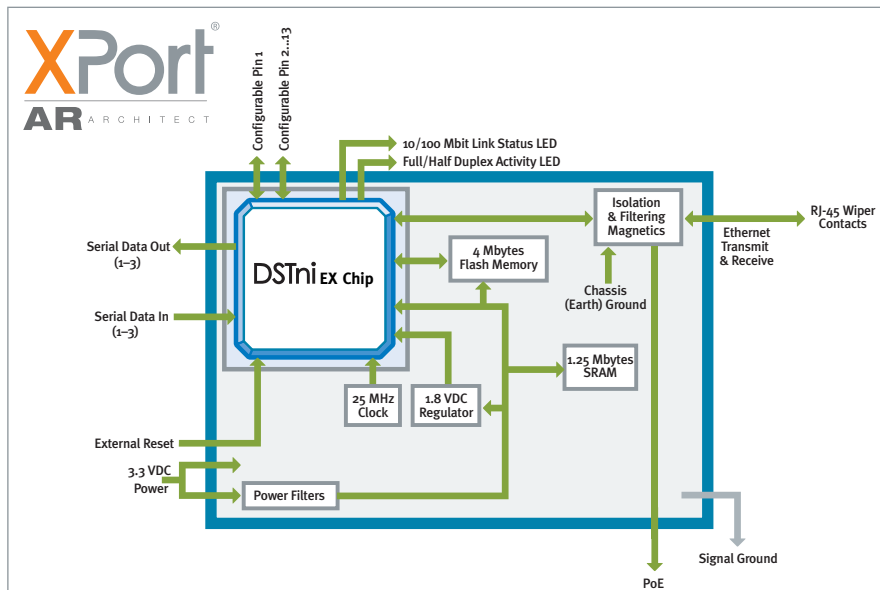

Warranty

2-year limited warranty

Included Software

Evolution Network Operating System
 MS Windows-based DeviceInstaller[™] and
 MS Windows-based Com Port Redirector

Part Number and Description

XP3002000-01R	XPort AR RoHS, Bulk, Extended Temperature -40° to 85°C
XP300200S-01R	XPort AR RoHS, Sample, Extended Temperature -40° to 85°C
XP300200K-01	XPort AR Evaluation Kit
EVSDK-01	Evolution Software Development Kit for XPort AR

XPort AR Evaluation Kits are available, contact Lantronix for details.

LANTRONIX[®]

15353 Barranca Parkway | Irvine | CA 92618 | USA | Tel: 800.526.8764 | Fax: 949.450.7249 | www.lantronix.com

© 2006, Lantronix, Inc. Lantronix and XPort are registered trademarks, and XPort Architect (AR), DSTni, DeviceInstaller and Machine2Mainstream are trademarks of Lantronix. All other trademarks are the property of their respective owners. Specifications subject to change without notice. All rights reserved. 910-477 09/06 DGS1000